

Felt composition 3

Product Fact Sheet



ex.t

info@ex-t.com / ex-t.com

Felt composition 3



Design By
Norm.Architects

Code
EXFELTCOMB3
EXFELTCOMB3BI

Category
Storage Units

Module Dimensions
30 x 15 x h 59.5 cm
Grid 2X1 59,5 x 15 x 30 cm
Square mirror 28,8 x 1 x h 30 cm
Tray with bowl 28,9 x 15 x h 1,6 cm
Tray 28,9 x 15 x 0,5 cm

Materials
Matt varnished metal

Colours

- Black - RAL 9004
- White - RAL 9016

Weight
Product 5.2 kg
Packaging kg

Packaging Dimensions
-

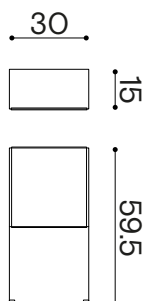

Felt composition 3

Scale 1:10

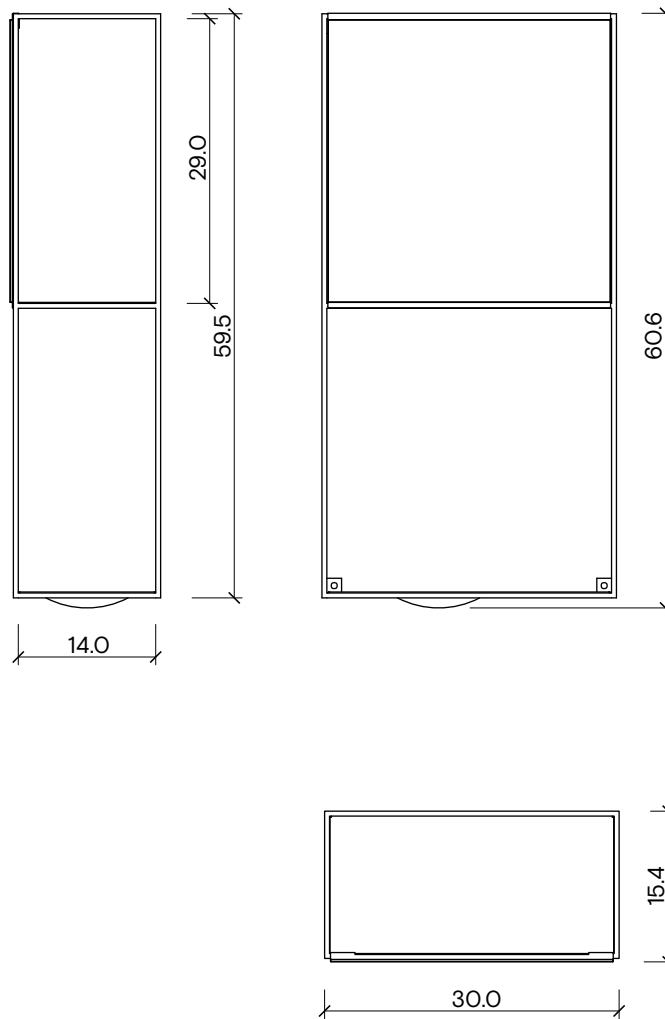

GRID 2X1

EXFELTGRID2X1NE

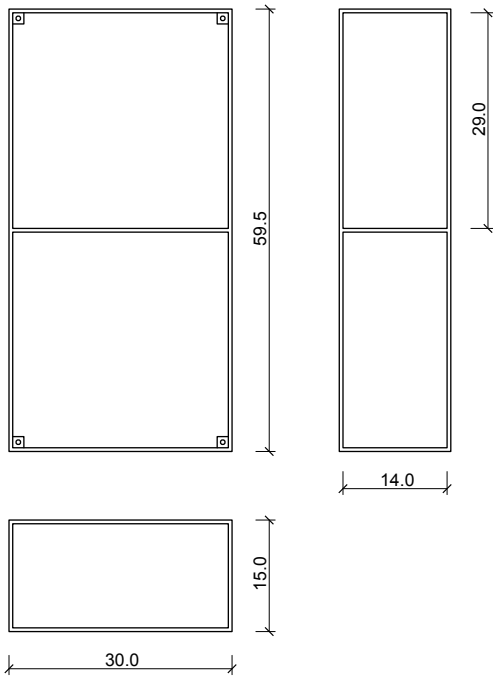

SQUARE MIRROR

EXFELTGRIDSPQUAD

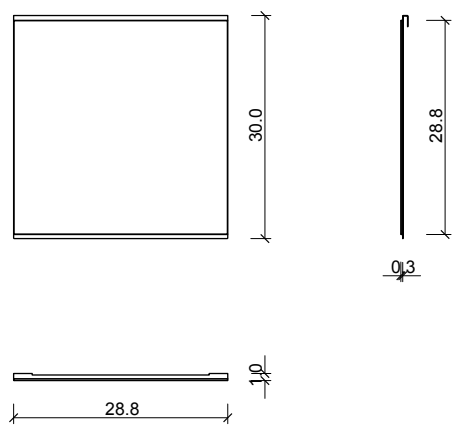

TRAY WITH BOWL

EXFELTGRIDVASCIO TNE

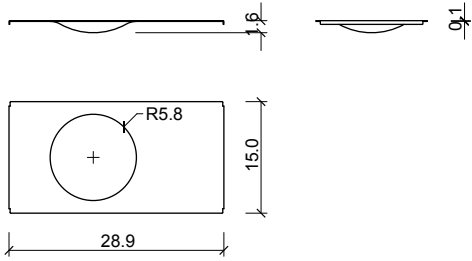

TRAY WITH BOWL

EXFELTGRIDVASCIO TNE

