

A-A (1 : 10)

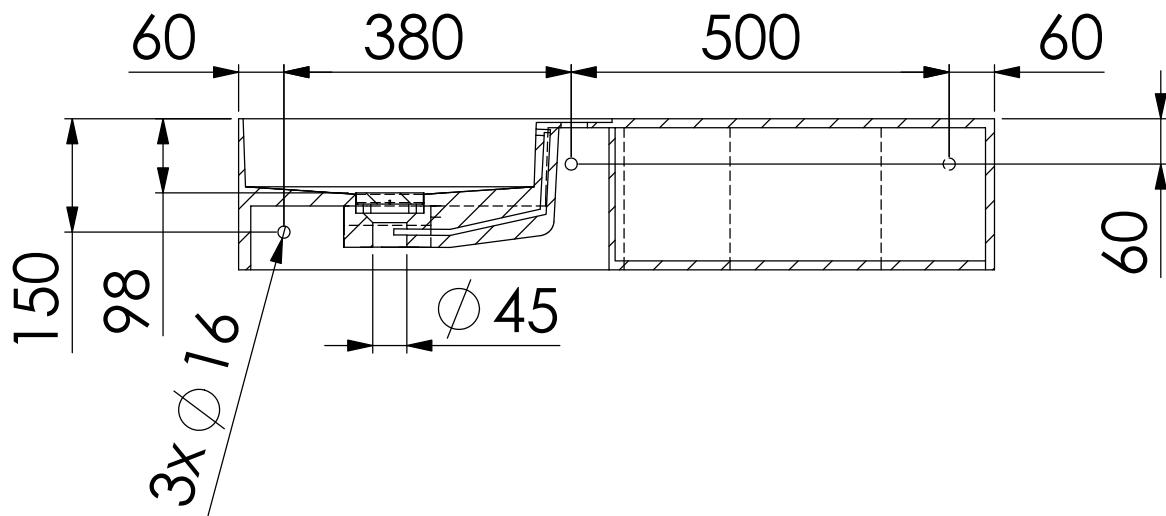

(Toleranz +/- 2 mm)