

STEINBERG



Fertigmontageset

Art.Nr.390 4223 3

Installation

<p>1</p>	<p>2</p> <p>S30</p> <p>1</p>
<p>3</p>	<p>4</p> <p>Switch ON</p> <p>ON</p> <p>OFF</p>
<p>5a1</p> <p>Switch ON</p>	<p>5a2</p> <p>While holding the knurled part on the cap with one hand tighten the lock sleeve with a locking wrench by the other hand. Ensure that the cap remains still during this process.</p> <p>Cap</p> <p>Lock sleeve</p>

Technische Zeichnung

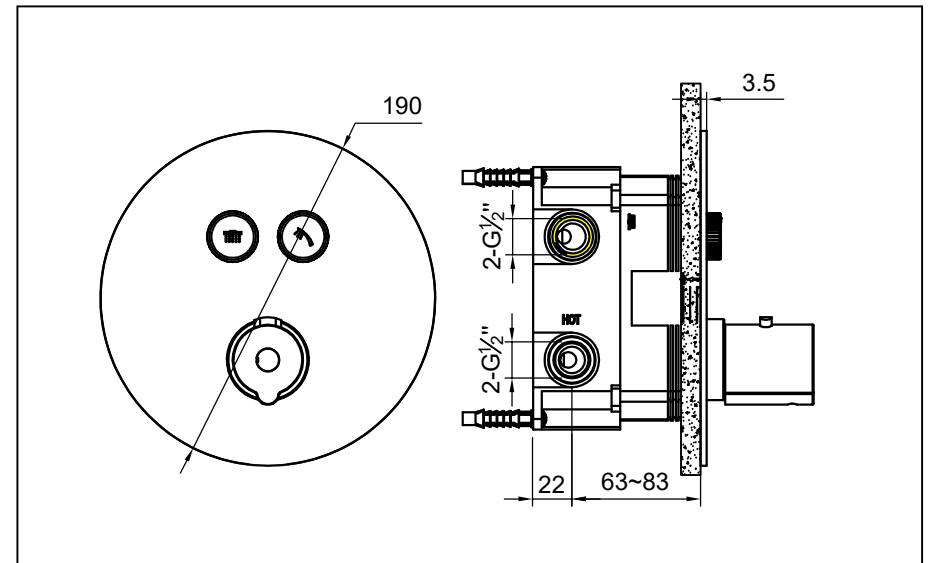

Installation

<p>5a3</p>	<p>5a4</p> <p>3.5mm thickness plates</p> <p>9mm thickness plates</p> <p>11mm thickness plates</p>
<p>5a5</p>	<p>5a6</p> <p>2</p> <p>1</p> <p>3</p>

STEINBERG



Fertigmontageset

Art.Nr.390 4223 3

Installation

<p>5a7</p> <p>1 2</p> <p>Chamfer facing outside</p>	<p>5a8</p> <p>3.5mm thickness plates 9mm thickness plates 11mm thickness plates</p>
<p>5a9</p>	<p>5a10</p> <p>1 2</p>
<p>5a11</p>	<p>5a12</p> <p>Switch ON =0 (v)</p>

Installation

<p>5a13</p> <p>While holding the knurled part on the cap with one hand tighten the lock sleeve with a locking wrench by the other hand. Ensure that the cap remains still during this process.</p> <p>Cap Lock sleeve</p>	<p>5a14</p> <p>Gently install the connecting rod onto the adjusting rod until it reaches the end.</p>
<p>5a15</p> <p>1 2 3</p> <p><math>-3 &lt; X \leq 0</math> <math>X &gt; 0</math></p>	<p>6</p> <p>38°C</p>
<p>7</p> <p>11-13mm</p> <p>ON OFF</p>	<p>8</p> <p>Dash on cartridge Stop collar 38°C Thermostatic cartridge Dash on extended spindle Extended spindle</p> <p>Keep the following parts aligned vertically as shown in above picture: the 38°C mark on the face plate, the dash on cartridge, and the dash on extended spindle.</p>
<p>9</p>	<p>10</p> <p>High Low HOT COLD</p>

STEINBERG



Fertigmontageset

Art.Nr.390 4223 3

Explosionszeichnung

